



# Non-Redundant Social Information Use in Avian Flocks with Multisensory Stimuli

Jacquelyn Randolet, Jeffrey R. Lucas & Esteban Fernández-Juricic

Department of Biological Sciences, Purdue University, West Lafayette, IN, USA

## Correspondence

Esteban Fernández-Juricic, Department of Biological Sciences, Purdue University, 915 W. State Street, West Lafayette IN 47907, USA

E-mail: efernan@purdue.edu

Received: September 2, 2013

Initial acceptance: October 22, 2013

Final acceptance: December 29, 2013

(S. Foster)

doi: 10.1111/eth.12212

**Keywords:** alarm calls, antipredator behavior, collective detection, flight initiation distance, robots, vigilance

## Abstract

Animals generally live in multisensory worlds; however, our understanding of multisensory perception is rather limited, despite its relevance for explaining the mechanisms behind social interactions, such as collective detection while foraging in groups. We tested how multisensory stimuli affected the antipredator behavior of dark-eyed juncos (*Junco hyemalis*) using alarm calls as an auditory signal and flushing behavior as a visual cue. We varied the degree of risk within the group by manipulating the number of group mates alarm calling and/or flushing using robotic birds. We assumed that alarm calling and flushing were redundant stimuli and predicted that they could generate one of three types of responses (enhancement, equivalence, or antagonism) depending on the mechanism of multisensory perception. We set up an artificial flock with three robotic juncos surrounding a live junco and controlled for multiple confounding factors (e.g., identity of the focal, body mass, food deprivation time). We found that the degree of alarm of live juncos increased when at least one robot flushed. However, the time it took the live individuals to react to the robots' behavior increased, rather than decreased, with at least one alarm call. This could be the result of an orienting response or sensory overload, as live juncos increased scanning behavior after being exposed solely to alarm calls. Contrary to some theoretical assumptions, alarm calling and flushing behavior elicited independent unimodal responses, suggesting that they are non-redundant stimuli and that together they could reduce the occurrence of false alarms and facilitate flock cohesion.

## Introduction

Animals living in groups use social information to make foraging and antipredator decisions (Giraldeau & Caraco 2000; Krause & Ruxton 2002; Valone & Templeton 2002). Researchers have identified two sources of information available from conspecifics in groups: cues and signals. A cue is a behavior inadvertently left by an individual (i.e., not directed to conspecifics) but that can be used by group mates as a source of information (Danchin et al. 2004). Examples include olfactory cues left by individuals when alarmed (Ward & Mehner 2010) or the visual cues of group mates escaping in response to some threat (Cresswell 1994). In contrast, a signal is a behavior

produced by an individual that is generally directed toward conspecifics (Bradbury & Vehrencamp 2011). Signals include alarm calls, mobbing calls, and tail flicks, which are used to communicate the presence of a potential threat (Caro 2005).

Based on the framework of collective detection, cues and/or signals can be used by individuals in foraging groups to indicate the presence of potential predators, thereby enhancing predator detection and reducing mortality (reviewed in Roberts 1996; Krause & Ruxton 2002). However, both classes of information can be unreliable because they can be given when no specific threat is present (i.e., false alarms; reviewed in Caro 2005; Searcy & Nowicki 2005). Low levels of reliability can in turn cause misinformation

cascades in groups and missed foraging opportunities (Giraldeau et al. 2002), leading to increased costs of group living (Beauchamp & Ruxton 2007).

Generally, both cues and signals are given while animals forage in groups, sometimes simultaneously and in different sensory modalities. For instance, when yellow-bellied marmots detect predators, individuals may alert conspecifics by producing alarm calls (auditory signal) as well as quickly fleeing (visual cues) to cover (Collier et al. 2010). How these multisensory stimuli could affect the reliability of social information transfer in groups is unclear. This in part results from the fact that most of the empirical research on social information use in foraging groups has been focused on either a cue or a signal being manipulated within a single sensory modality (Munoz & Blumstein 2012; but see Partan et al. 2009, 2010). Nonetheless, multisensory stimuli in antipredator contexts could in principle provide more information about a predation risk (Munoz & Blumstein 2012).

The goal of this study was to assess how multisensory stimuli affected the antipredator behavior of dark-eyed juncos (*Junco hyemalis*, hereafter juncos). Juncos forage in flocks during the non-breeding season, decreasing their investment in vigilance in larger flocks (Lima 1988, 1995a). Junco vigilance behavior is not affected by the presence of vigilant or non-vigilant conspecifics (Lima 1995a). However, juncos have alarm calls (Hostetter 1961; Whitney 1968; Young 2012) that potentially prompt antipredator behavior in group mates (S. L. Lima, pers. comm.). Additionally, when a large proportion of a flock leaves in unison, this increases the chances that group mates also flush (Lima 1995b). The fact that juncos do not appear to pay attention to the vigilance behavior of group mates but respond to group mate alarm calling and flushing makes them an interesting model species for studies of multisensory information gathering because the complexity of antipredator social stimuli is reduced, simplifying the experimental design.

We used alarm calls as auditory signals and flushing behavior as visual cues and modified the potential degree of predation threat within a group by manipulating the number of group mates alarm calling and/or flushing. The rationale is that the probability of a perceived threat may increase with the number of individuals alarm calling (e.g., Sloan & Hare 2008) or flushing (Cresswell 1994; Lima 1994, 1995b; Roberts 1997; Cresswell et al. 2000) in a group. Moreover, the reliability of the information about this threat should be greater from multisensory stimuli as compared with information derived from single sensory modes. Varying the availability of social stimuli in groups can

be challenging because it involves manipulating the behavior of group mates (Fernández-Juricic & Kacelnik 2005). We decided to use robotic animals as an alternative approach to manipulate the auditory and visual stimuli in groups. As with any other technique, robots have pros and cons (reviewed in Webb 2000; Patricelli 2010; Krause et al. 2011). Nevertheless, the use of robotic animals has proven successful in social foraging scenarios with birds (Fernández-Juricic et al. 2006; Fernández-Juricic & Kowalski 2011).

We measured specific antipredator responses of live individuals to variations in the number of robotic group mates alarm calling and flushing. The responses included reaction time, degree of alarm in the response, and scanning and body movement behaviors. We used the conceptual framework of multimodal perception (Munoz & Blumstein 2012) to make qualitative predictions about responses to combinations of signals and cues. This framework is aimed at assessing the mechanisms by which animals process information from different sensory modalities. The basic tenet of this framework is that multisensory stimuli would reduce uncertainty in decision-making compared with unimodal stimuli because single sensory modalities are constrained physically (e.g., transmission properties) and in terms of information availability (e.g., signal relative to noise; Munoz & Blumstein 2012).

Given the lack of empirical evidence on how our model species processes multimodal information, we followed established theoretical analyses (e.g., Pulliam 1973; Lima 1987; Proctor et al. 2001) by assuming that alarm calling and flushing behaviors would cause the same type of antipredator response in juncos. Independent responses of juncos in response to each unimodal stimulus are consistent with this assumption (Lima 1995b; Young 2012). Therefore, we deemed alarm calling and flushing behaviors as redundant (i.e., each isolated component generates a qualitatively similar response to the multimodal signal), and following Munoz & Blumstein's (2012) framework, we expected one of three alternative scenarios: enhancement, equivalence, or antagonism.

Under enhancement, live birds would show stronger antipredator responses (i.e., higher degree of alarm, shorter reaction times, increased scanning, and decreased body movement) when the signal and cue are combined compared with when they are presented independently (Munoz & Blumstein 2012). Enhancement could be the result of the multisensory stimuli being more salient than unimodal stimuli. Under equivalence, we would expect live birds not to differ in their antipredator behavior (similar degrees

of alarm, reaction time, scanning, and body movement) when the signal and cue are presented simultaneously vs. independently (Munoz & Blumstein 2012). Under antagonism, live birds would show weaker antipredator responses (lower degree of alarm, longer reaction time, decreased scanning, and increased body movement) when the signal and cue are presented simultaneously compared with when they are presented independently (Munoz & Blumstein 2012). Antagonism could result from multisensory stimuli becoming less salient than single sensory stimuli due to sensory overload. The adaptive value of these scenarios lies in identifying behavioral strategies that would optimize foraging efforts, while reducing the investment in antipredator vigilance (Munoz & Blumstein 2012). Moreover, understanding the responses to multisensory stimuli associated with potential threats in a social foraging context has implications for explaining the role of sensory systems in antipredator behavior contexts (Hemmi & Zeil 2005).

**Methods**

The experiment was conducted at the Ross Reserve (+40° 24' 35.16" N, -87° 4' 9.71" W), Indiana, USA. We captured and color-banded 13 juncos from the local population. Individuals were housed in auditory, visual, and physical contact with 6–7 conspecifics per aviary. Individuals were fed a mix of millet and thistle *ad libitum*, and provided with mealworms 2–3 times a week.

We conducted our experiments in an indoor experimental arena, surrounded with a 1.7 m tall black cloth to minimize visual noise. We set up an artificial flock composed of three robotic juncos positioned in a circle around a live junco, each 2.5 m apart from one another (details in Appendix S1). The live junco was

in an enclosure, which could have limited its antipredator behavior, although previous studies have shown that birds in enclosures have similar vigilance behavioral responses to those of free birds (e.g., Fernández-Juricic et al. 2006, 2011). All robots were positioned so that the focal bird viewed the left side of each robot's body. A speaker was placed 1.3 m from the robot, hidden behind black cloth from the live bird's view.

The three robots were built using skins of deceased juncos. Using different servos (details in Appendix S2), we manipulated the robot head movements (i.e., moving its head from side-to-side) to simulate scanning while head-up, body movement up and down to simulate pecking and scanning, and movement from the ground to the air by pulling the robot upwards to simulate flushing. Robot flushing was accomplished with a weight system using a jumper mechanism (Fig. 1). At the robot's chest, we had a fishing line that was connected to a loop using a necklace clasp at one end and weights to the other end (Fig. 1). The jumper mechanism consisted of two pieces of wood attached to each other (Fig. 1). At the top, we attached a servo whose arm was held at a 45° angle pointing upwards (Fig. 1). Another fishing line was attached to the weights that flushed the robot. The on-the-ground position was attained when the weights were held up. When the servo dropped its arm, it allowed the loop of the fishing line holding the weights to release and pull the robot upwards mimicking the flushing behavior (Fig 1). A similar robotic flushing behavior system was used successfully in Fernández-Juricic & Kowalski (2011).

Based on the behavior of free-living juncos recorded in a preliminary study, we programmed each robot to move its head 77 times/min and to peck 19 times/min. The intervals between head-up and head-down bouts were set haphazardly. Each robot

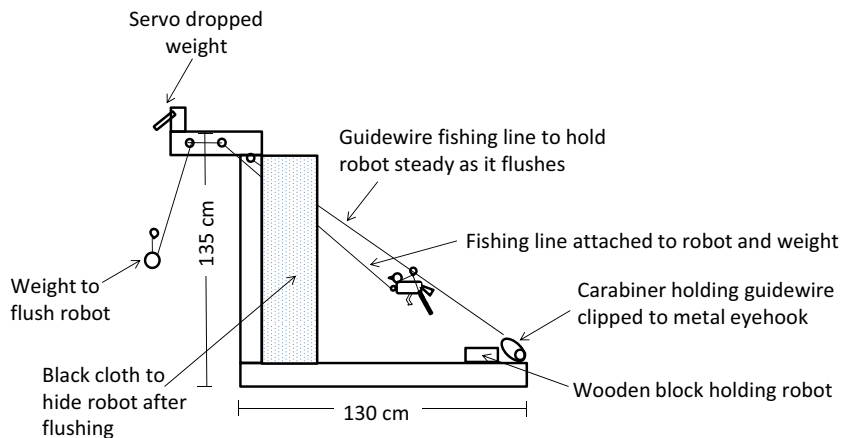

**Fig. 1:** Schematic diagram of the jumper mechanism for the robotic bird to mimic flushing behavior.

was programmed with the same sequence whose start was offset by at least 3 s so that the behaviors were not performed simultaneously. This sequence simulated a junco with low vigilance rates so that the robot alarm calling and flushing behaviors contrasted from the normal 'foraging' motions of the robots. Prior to the present study, we corroborated empirically that live dark-eyed juncos responded to robotic birds in similar ways as they did to live conspecifics (Appendix S3).

Alarm calls were recorded from three juncos captured 1 yr prior to this study (Fig. 2), but not used in this experiment. The only effective means of eliciting alarm calls occurred when juncos were placed in an enclosure and exposed to a stuffed cat predator. Alarm calls were recorded using a Sennheiser ME66 directional microphone placed 0.5 m from the enclosure. The microphone was connected to a Marantz PDM-690 Professional solid-state recorder recording at a sampling rate of 44.1 kHz. Sonograms of the three alarm calls used are presented in Fig. 2. We had difficulty getting a large enough pool of good quality alarm calls to use multiple exemplars in the different treatments for the playback component of this study. We tried to record these calls from 12 different wild-caught individuals, but only three responded. We also tried recording alarm calls from free-ranging birds,

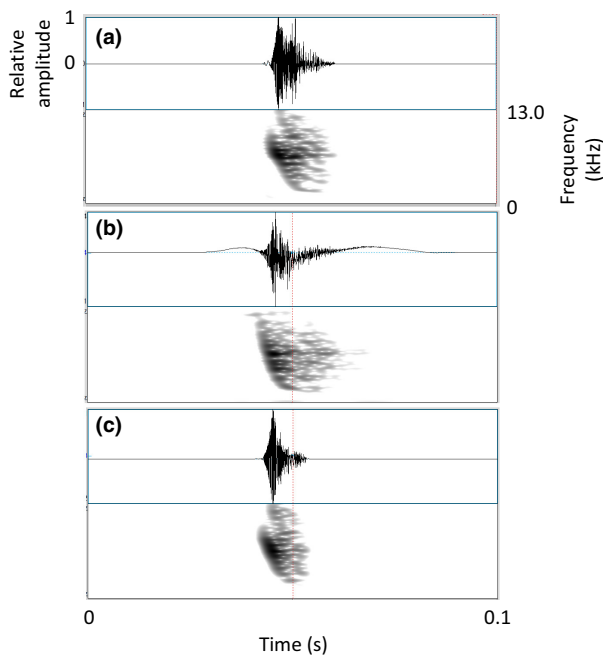

**Fig. 2:** Sonograms of three dark-eyed junco alarm calls (a-c) from different individuals that were used for playback purposes. Each pair of figures shows a waveform view (above) and a spectrogram (below).

but the quality of the recordings was not good enough for playbacks. Given these constraints, we paired each alarm call to a specific robot across treatments. Based on the structural properties of the alarm calls recorded (Fig. 2) in relation to previous descriptions of these dark-eyed junco calls (reviewed in Nolan et al. 2002) and consultations with an expert on this species (S. L. Lima, pers. comm.), we believe that the exemplars we used were representative of this species alarm calls. To determine whether the alarm call exemplars used could have an unequal effect on our response variables, we ran our statistical models (see Results) including the identity of the exemplar alarm call and found no significant effects (results available upon request). This suggests that the exemplars used appeared to be fairly uniform in their effect on the birds. Nevertheless, we acknowledge that we cannot reach any conclusion about the alarm calls in general and that our inferences are restricted to the three alarm call exemplars used.

During the trials, we played back the alarm calls from a Dell Latitude D610 computer to a Behringer mixer board (BCA 2000) connected to a Saul Mineroff amplified speaker (one speaker per alarm call). Playback levels were standardized to 75 dB measured 1 m from the speaker using a digital sound level meter. This is the approximate intensity of junco alarm calls in the field (S. L. Lima, pers. comm.).

Our experimental design consisted of two main independent factors reflecting variation in the availability of auditory signals and visual cues: (1) number of robots emitting alarm calls (0, 1, 3 alarm calls) and (2) number of robots flushing (0, 1, 3 robots flushed). These treatment levels represent a relatively large range of variation in the degree of alarm within a flock (Cresswell 1994; Roberts 1997; Sloan & Hare 2008). We combined the three levels of each independent factor, but we did not include the double null treatment (no flushing and no alarm calling) to minimize the number of treatments each bird was subjected to. Nonetheless, each trial started with a pre-treatment observation period, thus providing an estimate of the baseline behavior of each bird. We followed a repeated-measures design by exposing each of our 13 live individuals to each of the eight treatments in a random order on different days. The position of each robot and alarm call was randomized for each trial to minimize habituation effects.

A trial consisted of releasing a focal bird into its enclosure and allowing it to forage for 2 min (on average, it took focals  $13.0 \pm 2.8$  s to begin foraging). After 2 min of foraging, one of the eight treatments was applied (on average, a treatment application

lasted  $2.0 \pm 0.6$  s), and we continued recording the focal for an additional 2 min. Therefore, each trial consisted of a pre-treatment phase, a treatment phase, and a post-treatment phase. In treatments with more than one alarm call, we played the alarm calls simultaneously, and in those with more than one robot flushing, all flushes were completed within 1 s. In treatments consisting of both alarm calling and robots flushing, the calls were played first and the robots were flushed <1 s afterward. This was due to a slight delay required to move the computer mouse from playing the alarm call to triggering the robot flushing. Nevertheless, this sequence generally mimicked the natural behavior of juncos in flocks.

We recorded the behavior of both the robots and the live birds with four cameras connected through coaxial CBC cables to a Ganz DVR and quad-splitter recording unit. One camera was focused on a lateral view of the live bird's enclosure, and the other three cameras were focused on the robots in a way that we could observe the flushing robot disappear behind the screening after flushing (Appendix S2). We recorded the audio of all trials using a Sennheiser ME66 directional microphone suspended 1 m above the live bird enclosure. The microphone was connected to a Marantz PDM-690 Professional solid-state recorder recording at a sampling rate of 44.1 kHz.

Animals can display antipredator responses through different behaviors which may be only weakly correlated (Lind & Cresswell 2005). For that reason, we used four different types of responses of the live juncos to each treatment: reaction time, degree of alarm in the response, scanning rate, and body movement rate.

Reaction times can influence the speed of the response to a threat (Kaby & Lind 2003; Blackwell et al. 2009). The following technique was used to determine the reaction time of each live bird to a stimulus (auditory, visual, or both). We used Virtual-Dub (Avery Lee, Version 1.9.11) to record the focal's behavior for 5 s (30 frames per s) frame-by-frame

before a stimulus was presented (pre-stimulus) to establish its baseline behavior. After the presentation of the stimulus, we continued the frame-by-frame assessment until there was a change in its behavior (if any) until 3 s after the treatment ended. The number of frames that elapsed between the onset of the first stimulus and the frame with the first observed behavioral responses of the live individual was defined as the reaction time. If an individual did not exhibit any changes from baseline behavior within 3 s of the end of a stimulus, we assigned them a reaction time value of 95 frames (this occurred in 14.4% of the trials), which was outside of the 3 s range. For clarity, we presented reaction time as means  $\pm$  SE in s.

The types of behaviors that animals exhibit during a predator-prey encounter are a proxy of how alarmed they are (Lima & Dill 1990). In the context of our study, the degree of alarm was broken up into six different categories (Table 1) based on typical junco responses to predators (Lima 1995b; Nolan et al. 2002). Using the same frame-by-frame analysis as described before, we estimated the reaction time based on the first behavioral response of the live individual (Table 1). We needed an index for ranking the different levels of alarm measured for each bird. In an effort to ensure that the specific index used to rank bird behavior would not bias our results, we devised three different indices based on three different ranking criteria: alarm<sub>1</sub>, alarm<sub>2</sub>, and alarm<sub>3</sub> (Table 2). In all of these indices, the higher the value, the more alarmed the individual was considered to be in response to a given treatment.

The first index (alarm<sub>1</sub>) ranked behavioral responses as: flushing >alarm calling >crouching >movement >other in a hierarchical manner (Table 2), such that flushing included any combination of behaviors with flushing, alarm calling included any combination of behaviors with alarm calls but without flushing, crouching included any combination of behaviors with crouch but without alarm calls and flushing, etc. This

**Table 1:** First behavioral responses of live birds to robotic birds showing antipredator behavior

Behavior	Description	Number of times observed
1. Change in head position	An individual moved its head abruptly and quickly (sideways or tilting head movements changing from head-down to head-up, etc.)	60
2. Stretched neck	An individual in the head-up position stretched its neck to full extend	2
3. Crouch	An individual shifted its entire body close to the ground	10
4. Movement	An individual propelled its body forward using one or both legs, walking or hopping	13
5. Flush	An individual in a quick sequence pushed against the ground, extended its wings, and flew off the ground	3
6. Body turn	Body twisted from a given position to another without moving feet	1



**Table 2:** Rating of behaviors to determine alarm level of an individual

Behaviors observed	Alarm <sub>1</sub>	Alarm <sub>2</sub>	Alarm <sub>3</sub>	Observed frequency
Movement, crouch, flush	5	9	9	1
Crouch, flush	5	8	8	1
Flush	5	7	7	6
Movement, alarm call	4	6	4	7
Alarm call	4	5	2	2
Movement, crouch	3	4	6	7
Crouch	3	3	5	2
Movement	2	2	3	35
Other <sup>a</sup>	1	1	1	43

<sup>a</sup>Change in head position, while head-up, stretched neck, and body turn (Table 1).

ranking followed patterns described in Lima & Bednekoff (1999), Kaby & Lind (2003), Whittingham et al. (2004), and Tisdale & Fernández-Juricic (2009). For alarm, we assigned the strongest response to an animal that flushed, irrespective of any other behavior it exhibited, as it involves an abrupt behavioral change from the baseline (e.g., foraging). Alarm calling was considered to have a greater degree of alarm than moving and crouching because alarm calls have evolved as signals associated with risky scenarios (Caro 2005). Crouching was considered to have a greater degree of alarm than moving because it is a behavioral response to predator attacks to reduce visual saliency (i.e., the individual freezes) and it is a precursor to flying if the degree of risk increases (i.e., predator targets the individual). Moving was considered to have a greater degree of alarm than any other behavior not listed above (Table 2) as it involved a change in the position of the live bird likely associated with gathering more information about the source of the potential threat. Finally, other behaviors represented the lowest degree of alarm and included changing in head position while head-up, stretching neck, and body turning (Table 2), which are usually associated with vigilance behavior.

The second index (alarm<sub>2</sub>) assumed an additive rather than hierarchical ranking of stimuli (i.e., each combination of behaviors was assigned a different category; Table 2) with the intensity similar to alarm<sub>1</sub>. Thus, each behavior was assumed to contribute to the level of alarm (e.g., crouch + alarm calling ranked higher than only alarm calling), and the behavior with a higher degree of alarm was weighted more heavily in the ranking (crouching + flushing ranked higher than crouching + movement).

The third index (alarm<sub>3</sub>) reflected the energetic costs the live bird may have incurred in responding to

the robots. We based the ranking on the approximate amount of energy spent per unit time (Clark 2012) and assumed the following overall ranking: flushing >crouching >movement >alarm call >other (Table 2). Body movements that involved lifting more mass (e.g., flushing) were assumed to require more energy expenditure per unit time (Nudds & Bryant 2000; van den Hout et al. 2010) compared with vocal behaviors (Horn et al. 1995; Oberweger & Goller 2001). We also considered combinations of behaviors where each behavior was assumed to contribute to the level of alarm and the behavior with the higher energetic expenditure per unit time got weighted more heavily in the ranking (Table 2).

Scanning and body movement behaviors indicate when a bird is investing more time in vigilance than in foraging activities (Fernández-Juricic et al. 2011). We used the head-movement rate to measure scanning behavior (Jones et al. 2007), as it better reflects how birds gather information with their visual systems (Fernández-Juricic 2012) and engage in different visual tasks (e.g., visual search, visual fixation; Fernández-Juricic et al. 2011). We defined a head-movement event as the live bird moving its head in any direction at or above the horizontal plane, and a body movement event was the live bird walking, hopping, or running while on the ground. We used JWatcher 1.0 (Blumstein & Daniel 2007) to code the behaviors in the three phases of the trial (pre-stimulus, during treatment, and after treatment). A student (M. Elmore) coded all the videos after she reached an intra-observer error <5% between repeated measurements on the same video sequence.

Food deprivation time (i.e., the duration of time the birds were given no access to food prior to the experiment to motivate them to forage; range: 6–9 h) and body mass (birds were weighed before the start of each trial; range: 14–21 g) were recorded as potential confounding factors. We also measured ambient temperature (range: 5.8–29°C) using a Kestrel 3500 pocket weather meter and the ambient light intensity (range: 1670–2670 lux) with a Mastech digital illuminance/light meter LX1330B.

### Statistical Analyses

Our response variables were as follows: (1) reaction time (number of frames until the focal responded to the robots), (2–4) the degree of alarm (scores from indices alarm<sub>1</sub>, alarm<sub>2</sub>, alarm<sub>3</sub>; each treated as a separate response variable) of the live bird in response to the robots (unitless; higher values indicated higher

degree of alarm), (5) head-movement rate (number of changes in head position per min), and (6) body movement rate (number of walks, hops, or runs per min). We used general linear mixed models (Proc Mixed-SAS) to analyze these six dependent variables in relation to number of alarm calls, number of flushes, and their interaction with the Kenward–Rogers algorithm used to calculate the denominator degrees of freedom. We also included food deprivation time, ambient temperature, and body mass as covariates. In the case of head-movement rate and body movement rate, we also included another factor, trial phase, and its interactions with number of robots alarm calling and flushing. Trial phase had three levels: (1) pre-stimulus (to establish baseline rates), (2) presentation of stimuli (robots alarm calling and/or flushing), and (3) post-stimulus (after robot alarm called and/or flushed).

Light intensity has been shown to influence anti-predator behavior through glare effects (Fernández-Juricic & Tran 2007; Fernández-Juricic et al. 2012). Additionally, we designed our experiment to expose every focal bird to the robots several times, which could lead to habituation effects (Fernández-Juricic et al. 2006). We tested for the potential confounding effects of these two factors. Ambient light intensity and the order of exposure to the treatments did not significantly affect the degree of alarm of the response (light:  $F_{1,101}$  varied from 1.85 to 2.20,  $p > 0.142$  for the difference indices; order:  $F_{1,99.5}$  varied from 0.28 to 1.25,  $p > 0.266$  for the difference indices), reaction time (light:  $F_{1,101} = 0.24$ ,  $p = 0.628$ ; order:  $F_{1,101} = 0.01$ ,  $p = 0.973$ ), or the body movement rate (light:  $F_{1,166} = 0.38$ ,  $p = 0.539$ ; order:  $F_{1,108} = 0.35$ ,  $p = 0.557$ ). Consequently, we did not include these two factors in our final tests. However, ambient light intensity ( $F_{1,160} = 4.27$ ,  $p = 0.040$ ), but not the order of exposure to the treatments ( $F_{1,110} = 0.98$ ,  $p = 0.323$ ), significantly influenced the head-movement rate; therefore, we included the former factor in the final statistical models.

We log-transformed the three alarm indices and body movement rates to meet the assumptions of normality of residuals and homogeneity of variances in the general linear models.

### Results

We observed juncos flushing within 3 s of a stimulus presentation in 8/104 trials and juncos emitting alarm calls in 8/104 trials. We never observed a focal bird both flushing and alarm calling within the 3-s interval.

Reaction time was not affected significantly by the number of robots flushing (Table 3). In contrast, the number of alarm calls had a significant effect on the time it took the live bird to respond to the robots (Table 3; Fig. 3). The trend was longer reaction times when more alarm calls were played (0 alarm call,  $0.66 \pm 0.23$  s; one alarm call,  $1.26 \pm 0.18$  s; three alarm calls,  $1.57 \pm 0.18$  s). We only found significant differences in *post hoc* tests between no alarm calls and one alarm call ( $t_{85.9} = -2.19$ ,  $p = 0.032$ ), and no alarm call and three alarm calls ( $t_{85.1} = -3.43$ ,  $p < 0.001$ ). However, reaction times did not vary significantly between one vs. three alarm calls ( $t_{84.7} = -1.43$ ,  $p = 0.156$ ). No interactions or confounding factors had a significant effect on reaction time (Table 3).

The degree of alarm of the response (log-transformed) to the robots was not affected significantly by

**Table 3:** General linear mixed model results on reaction time and the degree of alarm index (Alarm<sub>1</sub>, Alarm<sub>2</sub>, and Alarm<sub>3</sub>) indicating the response toward the number of robotic birds alarm calling (0, 1, 3) and flushing (0, 1, 3), food deprivation time, body mass of the live birds, and ambient temperature

	F	df	p
<b>Reaction time</b>			
Number of alarm calls	5.76	2,82.4	<b>0.005</b>
Number of flushes	0.72	2,82.3	0.489
Number of alarm calls X number of flushes	0.97	3,82.2	0.411
Food deprivation time	2.21	1,90.6	0.141
Ambient temperature	0.05	1,91.6	0.826
Body mass	0.41	1,41.1	0.527
<b>(log) Alarm<sub>1</sub></b>			
Number of alarm calls	0.46	2,81.7	0.633
Number of flushes	4.63	2,81.6	<b>0.013</b>
Number of alarm calls X number of flushes	0.54	3,81.7	0.659
Food deprivation time	6.77	1,88.5	<b>0.011</b>
Ambient temperature	1.77	1,93	0.187
Body mass	2.06	1,55.4	0.157
<b>(log) Alarm<sub>2</sub></b>			
Number of alarm calls	0.60	2,81.7	0.552
Number of flushes	3.75	2,81.6	<b>0.028</b>
Number of alarm calls X number of flushes	0.40	3,81.7	0.750
Food deprivation time	7.73	1,87.9	<b>0.007</b>
Ambient temperature	1.58	1,92.9	0.212
Body mass	2.65	1,58.3	0.109
<b>(log) Alarm<sub>3</sub></b>			
Number of alarm calls	0.44	2,81.4	0.647
Number of flushes	8.30	2,81.3	<b>&lt;0.001</b>
Number of alarm calls X number of flushes	0.41	3,81.7	0.743
Food deprivation time	5.25	1,88.8	<b>0.024</b>
Ambient temperature	3.54	1,92.9	0.063
Body mass	49.1	1,49.1	0.393

The alarm indices were log-transformed for these analyses. Significant effects ( $p < 0.05$ ) are listed in bold.

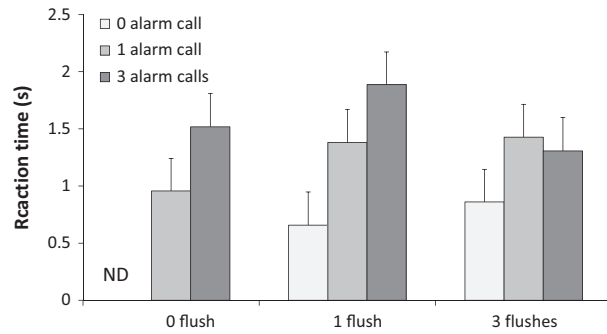

**Fig. 3:** Mean ( $\pm$  SE) reaction time of a live dark-eyed junco in relation to the number of robotic birds flushing and alarm calling. ND = no data were collected for no alarm call and no robot flushing.

the number of alarm calls played (Table 3). However, the number of robots flushing significantly influenced the degree of alarm (Table 3; Fig. 4). This result was consistent across each of the three indices studied (alarm<sub>1</sub>, alarm<sub>2</sub>, alarm<sub>3</sub>; Table 3, Fig. 4). The trend was increasing degree of alarm with more robots flushed for alarm<sub>1</sub> (0 flush,  $0.12 \pm 0.05$ ; one flush,  $0.27 \pm 0.04$ ; three flushes,  $0.29 \pm 0.04$ ), alarm<sub>2</sub> (0 flush,  $0.14 \pm 0.07$ ; one flush,  $0.30 \pm 0.05$ ; three flushes,  $0.34 \pm 0.05$ ), and alarm<sub>3</sub> (0 flush,  $0.13 \pm 0.07$ ; one flush,  $0.37 \pm 0.05$ ; three flushes,  $0.44 \pm 0.05$ ). However, *post hoc* tests indicated significant differences between no flush and one flush (alarm<sub>1</sub>,  $t_{84.8} = -2.69$ ,  $p = 0.009$ ; alarm<sub>2</sub>,  $t_{84.8} = -2.30$ ,  $p = 0.024$ ; alarm<sub>3</sub>,  $t_{84.5} = -3.36$ ,  $p = 0.001$ ), and between no flush and three flushes (alarm<sub>1</sub>,  $t_{85.5} = -2.95$ ,  $p = 0.004$ ; alarm<sub>2</sub>,  $t_{85.5} = -2.72$ ,  $p = 0.008$ ; alarm<sub>3</sub>,  $t_{85.3} = -4.07$ ,  $p < 0.001$ ). The degree of alarm did not vary significantly between one and three flushes (alarm<sub>1</sub>,  $t_{83.9} = -0.44$ ,  $p = 0.664$ ; alarm<sub>2</sub>,  $t_{84} = -0.63$ ,  $p = 0.529$ ; alarm<sub>3</sub>,  $t_{83.5} = -1.03$ ,  $p = 0.307$ ). Additionally, food deprivation time significantly affected the level of alarm: individuals with longer food deprivation times showed less alarmed responses (Table 3). No other interaction or confounding factor was significant (Table 3).

Head-movement rate (an index of scanning behavior) varied significantly between the three phases of the trials (Table 4). Head-movement rates were higher after the presentation of the stimuli than during the pre-stimulus phase ( $199.50 \pm 3.65$  events/min), peaking during the presentation of stimuli ( $223.27 \pm 3.67$  events/min), and decreasing in the post-stimulus phase ( $176.72 \pm 3.66$  events/min). All pairwise *post hoc* comparisons between the different trial phases were significant ( $t_{177-195}$  varied between  $-5.74$  and  $-12.20$ ,  $p < 0.001$ ). We also found a significant interaction effect between the number of

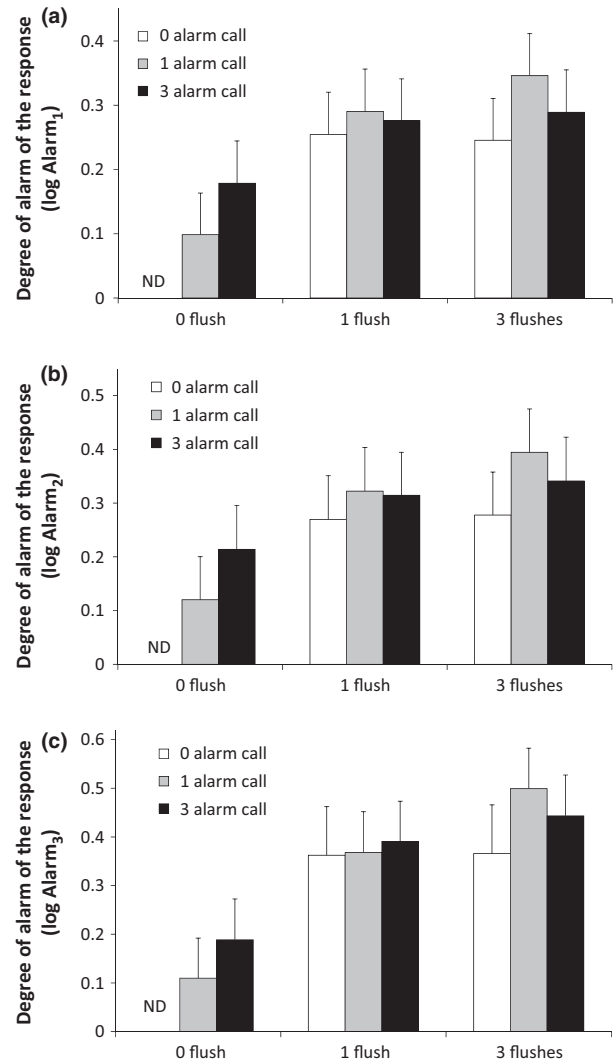

**Fig. 4:** Mean ( $\pm$  SE) degree of alarm of the response of a live dark-eyed junco in relation to the number of robotic birds flushing and alarm calling. Three indices of alarm were used (see text for details): (a) Alarm<sub>1</sub>, (b) Alarm<sub>2</sub>, and (c) Alarm<sub>3</sub>. ND = no data were collected for no alarm call and no robot flushing.

robots flushing and trial phase (Table 4; Fig. 5): head-movement rate was significantly higher during the presentation of the stimuli when no robots flushed (i.e., when only alarm calls were presented to the birds) than when either one ( $t_{248} = 4.18$ ,  $p < 0.001$ ) or three ( $t_{249} = 3.59$ ,  $p < 0.001$ ) robots flushed, without significant differences between one vs. three robots flushing ( $t_{257} = -0.61$ ,  $p = 0.540$ ; Fig. 5). All other factors and interactions were not significant (Table 4).

Body movement rate (log-transformed) varied significantly between the three phases of the trial (Table 4), being the lowest during the presentation of



**Table 4:** General linear mixed model results on head-movement rates and body movement rates of dark-eyed juncos in response to the number of robotic birds alarm calling (0, 1, 3) and flushing (0, 1, 3), trial phase (pre-stimulus, during stimulus, after stimulus), food deprivation time and body mass of the live birds, ambient temperature, and light intensity

	F	df	p
<b>Head-movement rate</b>			
Number of alarm calls	0.32	2,132	0.726
Number of flushes	2.42	2,124	0.093
Trial phase	78.04	2,174	<b>&lt; 0.001</b>
Number of alarm calls	1.69	3,141	0.173
X number of flushes			
Number of alarm calls X trial phase	1.97	4,212	0.101
Number of flushes X trial phase	5.98	4,207	<b>&lt; 0.001</b>
Number of alarm calls X number of flushes X trial phase	0.96	6,215	0.456
Food deprivation time	0.37	1,114	0.544
Ambient temperature	0.02	1,139	0.886
Body mass	0.31	1,53.5	0.578
Light intensity	0.36	1,153	0.549
<b>(log) Movement rate</b>			
Number of alarm calls	0.30	2,135	0.745
Number of flushes	0.95	2,129	0.388
Trial phase	18.51	2,192	<b>&lt; 0.001</b>
Number of alarm calls	1.91	3,141	0.131
X number of flushes			
Number of alarm calls X trial phase	0.41	4,218	0.780
X trial phase			
Number of flushes X trial phase	2.10	4,217	0.082
Number of alarm calls X number of flushes X trial phase	1.83	6,222	0.094
Food deprivation time	0.70	1,114	0.403
Ambient temperature	0.38	1,142	0.539
Body mass	5.03	1,117	<b>0.027</b>

Significant effects ( $p < 0.05$ ) are listed in bold.

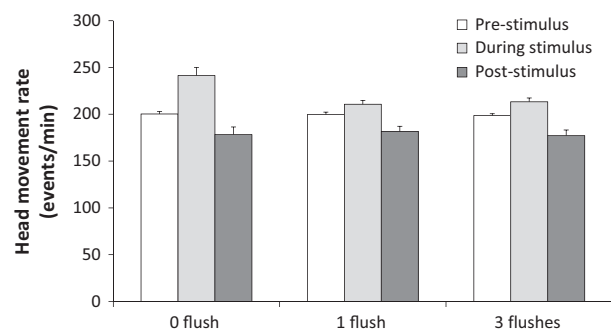

**Fig. 5:** Mean ( $\pm$  SE) head-movement rate of a live dark-eyed junco in relation to the number of robotic birds flushing and alarm calling in different phases of the trials: pre-stimulus (e.g., baseline head-movement rates), during the presentation of stimuli (robots alarm calling and/or flushing; see text for details), and after the presentation of stimuli.

the stimuli ( $0.322 \pm 0.089$ ) and intermediate after the stimuli ( $0.498 \pm 0.089$ ) compared with the pre-stimuli phase ( $0.685 \pm 0.089$ ), with all pairwise *post hoc* comparisons being significant ( $t_{198-215}$  varied between  $-2.97$  and  $5.80$ ,  $p < 0.01$ ). Body mass also affected body movement rates significantly: larger individuals moved more than smaller ones (Table 4). No other factors or interactions had a significant effect on body movement rates (Table 4).

**Discussion**

We found that multisensory stimuli affected different components of the dark-eyed junco antipredator behavior. In general, flushing behavior raised the degree of alarm, but alarm calls delayed reaction times. We did not find support for any single antipredator behavior being affected simultaneously by both alarm calling and flushing behavior. We assumed originally that alarm calling and flushing were redundant (e.g., Munoz & Blumstein 2012); however, our results suggest otherwise.

Our experimental design was generally based on the assumption that alarm calling and flushing are used by juncos to cue on the presence of potential threats (e.g., predators) while foraging in groups. Although we did not get the chance to test this assumption directly to avoid sensitization or habituation of our subjects, our data indirectly support this assumption, as the live juncos increased their scanning behavior and decreased their body movement during and right after the presentation of the stimuli (i.e., robots alarm calling, flushing) compared with the pre-stimulus phase (i.e., robots pecking and scanning). Juncos likely increased their head-movement rates to scan quickly different parts of the visual environment (Jones et al. 2007), hence enhancing visual coverage. A similar response in head-movement behavior has also been documented in brown-headed cowbirds (*Molothrus ater*) and Cherrie’s Tanagers (*Ramphocelus costaricensis*) foraging under risky conditions (Fernández-Juricic et al. 2011; Morrison 2011). The reduction in body movement rate (hopping, walking) when robots alarm called and/or flushed appeared to be the result of individuals allocating their time to information gathering through visual scanning as well as making themselves less detectable to potential predators (Caro 2005). An alternative interpretation of the transfer of social information is that juncos simply engaged in an orienting response, which can be triggered by any stimulus (i.e., conspecific alarm calling, vegetation moving) that led to an increase in sensory visual sensitivity and ultimately

an increase in exploratory behavior (e.g., eye, head, body re-orientation toward the source of information; Sokolov et al. 2002). We believe this may be unlikely given that the reaction of the juncos to the flushing and alarm calling of the robots was similar to that given to live group mates, as shown elsewhere (Lima 1995b; Young 2012). All this evidence is in accordance with the interpretation that there might have been some transfer of information in our artificial flocks (but see alternative interpretations below).

Avian flocks are dynamic entities as individuals come and go constantly. A flock mate flushing may not necessarily be associated with a predator attack but may instead reflect individuals seeking foraging opportunities in other patches. Consequently, if individuals leave a patch following every single 'false alarm', they could face an increase in energy expenditure as well as a loss of foraging opportunities (Beauchamp & Ruxton 2007). Previous studies have shown that the chances of individuals flushing increase with the number of flock mates flushing (Cresswell 1994; Lima 1995a; Roberts 1997; Cresswell et al. 2000), which could be the result of lower uncertainty of the cue associated with a real threat (i.e., flock mates escaping simultaneously to avoid a predator attacking). We found that the degree of alarm increased when group mates flushed, but the number of group mates flushing did not change this response significantly. There are two non-mutually exclusive potential explanations. First, even with a single group mate flushing, the proportion of the flock escaping would be very salient (25%) given the relatively small flock size we used. Second, group mates were quite close to the focal individual, which increases the chances of responding to their flushing behavior, as found in a study manipulating group mate behavior also with robotic birds (Fernández-Juricic & Kowalski 2011). Overall, the occurrence of the visual component of our multisensory stimuli may have decreased the benefits of foraging in the patch due to higher perception of risk.

In some species, individuals alarm call at higher rates in risky scenarios (solitary vs. group conditions, Reby et al. 1999; shorter distance to a threat, Warkentin et al. 2001; more dangerous predators, Zuberbühler 2000). Additionally, the number of individuals alarm calling can increase scanning behavior of group mates, as is the case with Richardson's ground squirrels (*Urocitellus richardsonii*; Sloan & Hare 2008). In our system, we found that junco head-movement rates increased when the alarm call exemplars we used were given without robots flushing. Thus, upon detecting alarm calls without further visual cues (e.g., flushing behavior), the perception of

risk may have led to enhanced visual vigilance to gather personal information as visual cues are more reliable in terms of spatial information (i.e., where the threat may be) (Talsma et al. 2010).

One of our most intriguing results is that the time it took live juncos to react to the exemplar alarm calls increased rather than decreased compared with conditions where no alarm calls were given (but robots flushed). Previous studies in terrestrial vertebrates have shown that animals actually respond sooner to a potential threat when in groups (reviewed in Stankovich & Blumstein 2005). Therefore, our result goes against one of the classic assumptions of collective detection (i.e., information about threats is transferred efficiently within groups; Pulliam et al. 1982; Lima 1987), because in this species alarm calling could actually reduce the benefits of group living by delaying responses to predator attacks. There are several non-mutually exclusive potential explanations for this result.

First, our experimental design may have biased live juncos' responses because our playbacks started shortly before flushing. However, our treatment order reflected field observations on this species. Additionally, the alarm calling effect on reaction time was evident even when no robots flushed. Second, live juncos may have perceived the alarm calls as not necessarily belonging to the robots surrounding them because the speakers were not in the same location as the robots. This may have inflated the perception of group size. We reran our statistical analyses using group size (adding the number of alarm calls and robots) as the independent factor, but it did not influence significantly reaction time or the degree of alarm (statistical results available upon request).

Third, junco alarm calling may not convey the same type of information as flushing in social foraging contexts compared with our assumption of redundant information across sensory modes. Alarm calls can reflect varying levels of threat, ranging from low-risk warning calls when predators are first sighted to distress calls when an attack has already started (Bradbury & Vehrencamp 2011). If what we considered to be an alarm call is actually a low-risk warning call, then there could have been some dissonance between the calls and flushing behavior when these stimuli were presented together. More importantly, low-risk warning calls may have actually triggered the vigilance response we observed (e.g., scanning rate) to better assess the degree of danger of the potential threat. However, this potential interpretation has to be taken with care because of the limited pool of different alarm calls for each playback due to logistical constraints (see Methods), which could have led to

some degree of pseudoreplication (Freeberg & Lucas 2009). Consequently, our degree of inference is restricted to the three exemplar alarm calls we used.

Fourth, limited attention may have influenced the response to alarm calls by constraining the ability of individuals to focus on different tasks (Dukas 2002). In our context, juncos may have taken longer to respond to alarm calls presented simultaneously relative to a single stimulus because of the higher processing load (i.e., sensory overload). Studies in humans have shown that when the sensory system becomes taxed, focusing on single or multiple tasks is more challenging (reviewed in Luck et al. 2000). Even under this auditory overload scenario, multisensory processing of the auditory and the visual stimuli may still be possible through changes in selective attention (Talsma et al. 2010). For instance, alarm calling may have triggered a bottom-up selective attention process given the saliency of these auditory stimuli relative to the baseline behavior of the robots (head-up, head-down). These auditory stimuli may have raised the level of awareness of the live juncos eliciting a top-down selective attention process to search visually for cues associated with high predation risk, which may have led to the enhanced degree of alarm when several robots flushed.

Overall, we did not find evidence that alarm calling and flushing behavior interacted in similar ways to influence the responses of juncos to information in an antipredator context, although we cannot generalize these results because we ran our experiment in indoor conditions. Despite this limitation, alarm calling and flushing produced different types of behavioral responses, suggesting that they may not be equivalent. This runs counter to the assumption of some theoretical studies that a stimulus in either the auditory (alarm calls) or visual (group mates flushing) modality can be used to transfer the same type of information about predator detection (Pulliam 1973; Pulliam et al. 1982; Proctor et al. 2001). From the perspective of the multisensory perception framework (Munoz & Blumstein 2012), our results suggest that alarm calling and flushing behavior are non-redundant stimuli that elicit independent unimodal responses (delaying reaction times and increasing the degree of alarm, respectively). The implication is that dark-eyed juncos, which have been shown not to pay attention to the vigilance behavior of group mates (Lima 1995a), may use this non-redundant system to minimize the occurrence of false alarms using stimuli in different sensory modalities to determine the *type* of threat. These non-redundant multisensory stimuli may ultimately facilitate group cohesion.

## Acknowledgements

We thank Ed Barlett, Amanda Ensminger, Luke Tyrrell, Alejandro Vélez Meléndez, Patrice Baumhardt, and Kelly Ronald for comments on an earlier version of the manuscript, and M. Elimore for coding videos. This study was funded by the National Science Foundation (IOS-0641550/0937187), the Indiana Academy of Sciences, and Purdue University.

## Ethical Standards

Experimental procedures were approved by Purdue Animal Care and Use Committee (#11-015).

## Literature Cited

- Beauchamp, G. & Ruxton, G. D. 2007: False alarms and the evolution of antipredator vigilance. *Anim. Behav.* **74**, 1199–1206.
- Blackwell, B. F., Fernández-Juricic, E., Seamans, T. W. & Dolan, T. 2009: Avian visual system configuration and behavioural response to object approach. *Anim. Behav.* **77**, 673–684.
- Blumstein, D. T. & Daniel, J. C. 2007: *Quantifying Behavior the JWatcher Way*. Sinauer, Sunderland, MA.
- Bradbury, J. W. & Vehrencamp, S. L. 2011: *Principles of Animal Communication*, 2nd edn. Sinauer, Sunderland, MA.
- Caro, T. 2005: *Antipredator Defenses in Birds and Mammals*. The Univ. of Chicago Press, Chicago, IL.
- Clark, C. J. 2012: The role of power versus energy in courtship: what is the 'energetic cost' of a courtship display? *Anim. Behav.* **84**, 269–277.
- Collier, T. C., Blumstein, D. T., Girod, L. & Taylor, C. E. 2010: Is alarm calling risky? Marmots avoid calling from risky places. *Ethology* **116**, 1171–1178.
- Cresswell, W. 1994: The function of alarm calls in redshanks, *Tringa totanus*. *Anim. Behav.* **47**, 736–738.
- Cresswell, W., Hilton, G. M. & Ruxton, G. D. 2000: Evidence for a rule governing the avoidance of superfluous escape flights. *Proc. R. Soc. Lond. B.* **267**, 733–737.
- Danchin, E., Giraldeau, L.-A., Valone, T. & Wagner, R. H. 2004: Public information: from nosy neighbors to cultural evolution. *Science* **305**, 487–491.
- Dukas, R. 2002: Behavioural and ecological consequences of limited attention. *Phil. Trans. R. Soc. B.* **357**, 1539–1547.
- Fernández-Juricic, E. 2012: Sensory basis of vigilance behavior in birds: synthesis and future prospects. *Behav. Proc.* **89**, 143–152.
- Fernández-Juricic, E. & Kacelnik, A. 2005: Increasing the costs of conspecifics scanning in socially foraging starlings affects vigilance and foraging behavior. *Anim. Behav.* **69**, 73–81.

- Fernández-Juricic, E. & Kowalski, V. 2011: Where does a flock end from an information perspective? A comparative experiment with live and robotic birds. *Behav. Ecol.* **22**, 1304—1311.
- Fernández-Juricic, E. & Tran, E. 2007: Changes in vigilance and foraging behavior with light intensity and their effects on food intake and predator detection in house finches. *Anim. Behav.* **74**, 1381—1390.
- Fernández-Juricic, E., Gilak, N., McDonald, J. C., Pithia, P. & Valcarcel, A. 2006: A dynamic method to study the transmission of social foraging information in flocks using robots. *Anim. Behav.* **71**, 901—911.
- Fernández-Juricic, E., Beauchamp, G., Treminio, R. & Hoover, M. 2011: Making heads turn: association between head movements during vigilance and perceived predation risk in brown-headed cowbird flocks. *Anim. Behav.* **82**, 573—577.
- Fernández-Juricic, E., Deisher, M., Stark, A. C. & Randolet, J. 2012: Predator detection is limited in microhabitats with high light intensity: an experiment with brown-headed cowbirds. *Ethology* **118**, 341—350.
- Freeberg, T. M. & Lucas, J. R. 2009: Pseudoreplication is [still] a problem. *J. Comp. Psychol.* **123**, 450—451.
- Giraldeau, L.-A. & Caraco, T. 2000: *Social Foraging Theory*. Princeton Univ. Press, Princeton, NJ.
- Giraldeau, L.-A., Valone, T. J. & Templeton, J. J. 2002: Potential disadvantages of using socially acquired information. *Phil. Trans. R. Soc. B.* **357**, 1559—1566.
- Hemmi, J. M. & Zeil, J. 2005: Animals as prey: perceptual limitations and behavioural options. *Mar. Ecol. Prog. Ser.* **287**, 274—278.
- Horn, A. G., Leonard, M. L. & Weary, D. M. 1995: Oxygen consumption during crowing by roosters: talk is cheap. *Anim. Behav.* **50**, 1171—1175.
- Hostetter, D. R. 1961: Life history of the Carolina Junco: *Junco hyemalis carolinensis* Brewster. *Raven*. **32**, 97—170.
- van den Hout, P. J., Mathot, K. J., Maas, L. R. M. & Piersma, T. 2010: Predator escape tactics in birds: linking ecology and aerodynamics. *Behav. Ecol.* **21**, 16—25.
- Jones, K. A., Krebs, J. R. & Whittingham, M. J. 2007: Vigilance in the third dimension: head movement not scan duration varies in response to different predator models. *Anim. Behav.* **74**, 1181—1187.
- Kaby, U. & Lind, J. 2003: What limits predator detection in blue tits (*Parus caeruleus*): posture, task or orientation? *Behav. Ecol. Sociobiol.* **54**, 534—538.
- Krause, J. & Ruxton, G. 2002: *Living in Groups*. Oxford Univ. Press, Oxford.
- Krause, J., Winfield, A. F. T. & Deneubourg, J.-L. 2011: Interactive robots in experimental biology. *Trends Ecol. Evol.* **26**, 369—375.
- Lima, S. L. 1987: Vigilance while feeding and its relation to the risk of predation. *J. Theor. Biol.* **124**, 303—316.
- Lima, S. L. 1988: Vigilance during the initiation of daily feeding in dark-eyed juncos. *Oikos* **53**, 12—16.
- Lima, S. L. 1994: Collective detection of predatory attack by birds in the absence of alarm signals. *J. Avian Biol.* **25**, 319—326.
- Lima, S. L. 1995a: Back to basics of anti-predatory vigilance: the group-size effect. *Anim. Behav.* **49**, 11—20.
- Lima, S. L. 1995b: Collective detection of predatory attack by social foragers: fraught with ambiguity. *Anim. Behav.* **50**, 1097—1108.
- Lima, S. L. & Bednekoff, P. A. 1999: Back to the basics of antipredatory vigilance: can nonvigilant animals detect attack? *Anim. Behav.* **58**, 537—543.
- Lima, S. L. & Dill, L. M. 1990: Behavioural decisions made under the risk of predation: a review and prospectus. *Can. J. Zool.* **68**, 619—640.
- Lind, J. & Cresswell, W. 2005: Determining the fitness consequences of antipredation behavior. *Behav. Ecol.* **16**, 945—956.
- Luck, S. J., Woodman, G. F. & Vogel, E. K. 2000: Event-related potential studies of attention. *Trends Cogn. Sci.* **4**, 432—440.
- Morrison, E. B. 2011: Vigilance behavior of a tropical bird in response to indirect and direct cues of predation risk. *Behaviour*. **148**, 1067—1085.
- Munoz, N. E. & Blumstein, D. T. 2012: Multisensory perception in uncertain environments. *Behav. Ecol.* **23**, 457—462.
- Nolan, V. Jr, Ketterson, E. D., Cristol, D. A., Rogers, C. M., Clotfelter, E. D., Titus, R. C., Schoech, S. J. & Snajdr, E. 2002: Dark-eyed Junco (*Junco hyemalis*), The Birds of North America Online (Poole, A., ed). Cornell Lab of Ornithology, Ithaca, NY. Retrieved from the Birds of North America Online: <http://bna.birds.cornell.edu/bna/species/716>.
- Nudds, R. L. & Bryant, D. M. 2000: The energetic cost of short flights in birds. *J. Exp. Biol.* **203**, 1561—1572.
- Oberweger, K. & Goller, F. 2001: The metabolic cost of birdsong production. *J. Exp. Biol.* **204**, 3379—3388.
- Partan, S. R., Larco, C. P. & Owens, M. J. 2009: Wild tree squirrels respond with multisensory enhancement to conspecific robot alarm behaviour. *Anim. Behav.* **77**, 1127—1135.
- Partan, S. R., Fulmer, A. G., Gounard, M. A. M. & Redmond, J. E. 2010: Multimodal alarm behavior in urban and rural gray squirrels studied by means of observation and mechanical robot. *Current Zool.* **56**, 313—326.
- Patricelli, G. L. 2010: Robotics in the study of animal behavior. In: *Encyclopedia of Animal Behavior Vol. 3* (Breed, M. & Moore, J., eds). Academic Press, Oxford, pp. 91—99.
- Proctor, C. J., Broom, M. & Ruxton, G. D. 2001: Modelling antipredator vigilance and flight response in group foragers when warning signals are ambiguous. *J. Theor. Biol.* **211**, 409—417.
- Pulliam, H. R. 1973: On the advantages of flocking. *J. Theor. Biol.* **38**, 419—422.



- Pulliam, H. R., Pyke, G. H. & Caraco, T. 1982: The scanning behavior of juncos: a game-theoretical approach. *J. Theor. Biol.* **95**, 89–103.
- Reby, D., Cargnelutti, B. & Hewison, A. J. M. 1999: Contexts and possible functions of barking in roe deer. *Anim. Behav.* **57**, 1121–1128.
- Roberts, G. 1996: Why individual vigilance declines as group size increases. *Anim. Behav.* **51**, 1077–1086.
- Roberts, G. 1997: How many birds does it take to put a flock to flight? *Anim. Behav.* **54**, 1517–1522.
- Searcy, W. A. & Nowicki, S. 2005: *The Evolution of Animal Communication: Reliability and Deception in Signaling Systems*. Princeton Univ. Press, Princeton, NJ.
- Sloan, J. & Hare, J. F. 2008: The more the scarier: adult Richardson's ground squirrels (*Spermophilus richardsonii*) assess response urgency via the number of alarm signalers. *Ethology* **114**, 436–443.
- Sokolov, E. N., Spinks, J. A., Näätänen, R. & Lyytinen, H. 2002: *The Orienting Response in Information Processing*. Lawrence Erlbaum Associates Inc, Mahwah, NJ.
- Stankowich, T. & Blumstein, D. T. 2005: Fear in animals: a meta-analysis and review of risk assessment. *Proc. R. Soc. Lond. B.* **272**, 2627–2634.
- Talsma, D., Senkowski, D., Soto-Franco, S. & Woldorff, M. G. 2010: The multifaceted interplay between attention and multisensory integration. *Trends Cogn. Sci.* **14**, 400–410.
- Tisdale, V. & Fernández-Juricic, E. 2009: Vigilance and predator detection vary between avian species with different visual acuity and coverage. *Behav. Ecol.* **20**, 936–945.
- Valone, T. J. & Templeton, J. J. 2002: Public information for the assessment of quality: a widespread social phenomenon. *Phil. Trans. R. Soc. B.* **357**, 1549–1557.
- Ward, A. J. W. & Mehner, T. 2010: Multimodal mixed messages: the use of multiple cues allows great accuracy in social recognition and predator detection decisions in the mosquitofish, *Gambusia holbrooki*. *Behav. Ecol.* **12**, 1305–1320.
- Warkentin, K. J., Keeley, A. T. H. & Hare, J. F. 2001: Repetitive calls of juvenile Richardson's ground squirrels (*Spermophilus richardsonii*) communicate response urgency. *Can. J. Zool.* **79**, 569–573.
- Webb, B. 2000: What does robotics offer animal behavior? *Anim. Behav.* **60**, 545–558.
- Whitney, N. R. 1968: White-winged Junco. Pp. 1021–1029. In *Life histories of North American cardinals, grosbeaks, buntings, towhees, finches, sparrows, and their allies*. Pt. 2 (Austin, O. L., Ed.) *U.S. National Museum Bulletin*. **237**.
- Whittingham, M. J., Butler, S. J., Quinn, J. L. & Cresswell, W. 2004: The effect of limited visibility on vigilance behavior and speed of predator detection: implications for the conservation of granivorous passerines. *Oikos* **106**, 377–385.
- Young, J. 2012: *What the Robbing Knows: How Birds Reveals the Secrets of the Natural World*. Houghton Mifflin Harcourt Company, New York, NY.
- Zuberbühler, K. 2000: Interspecific semantic communication in two forest monkeys. *Proc. R. Soc. Lond. B* **267**, 713–718.

### Supporting Information

Additional supporting information may be found in the online version of this article:

**Appendix S1:** Experimental layout.

**Appendix S2:** Building robotic juncos.

**Appendix S3:** Assessment of junco responses to conspecific robots.